



# SPECIFICATION

## N MALE CONNECTOR FOR 1/2" FEEDER CABLE

N connectors are available with 50Ω and 75Ω impedance. The frequency range extends to 11GHz, depending on the connector and cable type. The screw-type coupling mechanism provides a sturdy and reliable connection.

Connector styles are available for flexible, conformable, semi-rigid and corrugated cable types. Both crimp and clamp cable termination processes are used for this series. Special design techniques for this series of connectors have resulted in excellent levels of performance with regard to return loss (VSWR) and intermodulation distortion.

The N connector meets all technical requirements and covers high frequencies as well as legacy applications. Sealing against outer conductor and jacket by means of o-ring and 360° compression fit.

Watertight sealing in mated and unmated condition, i.e. reduced efforts during installation and improved security during operation

Tri-alloy plating i.e. extreme resistance against corrosion even under hardest climatic and environmental circumstances

RoHS compliant can be used on a global basis

Standards		IEC60169-16	
<b>Electrical Characteristics</b>		<b>Mechanical Characteristics</b>	
Contact resistance inner conductor	≤1.0 mΩ	Recommended coupling torque	4-6Nm
Contact resistance outer conductor	≤1.0 mΩ	Durability (mating cycles)	≥500
Insulation resistance	≥ 5.0GΩ	Material: spring contacts	Brass
Voltage proof	2.5KV/50Hz	Material: outer conductor	Brass
Impedance	50 Ω	Material: other metal parts	Brass
Return loss: Straight style	≥ 30.5 dB/1GHz; 19.1dB/6GHz	Material: insulators	PTFE
Return loss: Angle type	≥ 30.5 dB/1GHz; 19.1dB/6GHz	Plating: Inner conductor	Ag/Au
Working voltage	1KV/50Hz	Plating: Outer conductor	Ni/Tri-alloy
Frequency range up to	11GHz	Plating: Other metal parts	Ni/Tri-alloy

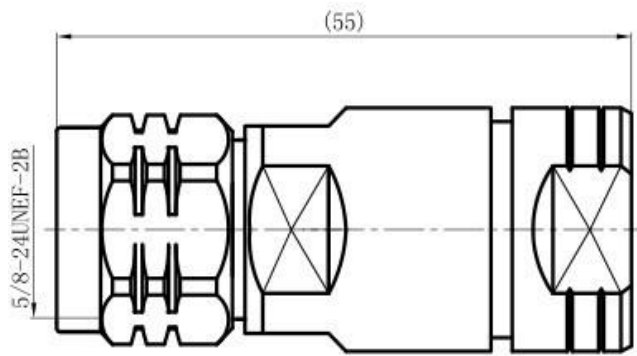

Part Number: N-M 1/2

Dimensions are in millimeters

**Interface**

According to IEC 60169-16

**General Specifications**

Cable Size	1/2"
Cable Type	Foam Dielectric
Connector Interface	N
Sealing Method	Sealing rubber and shrinking sleeve
Gender	Male

**Electrical**

Characteristic Impedance	50 ohm
Frequency Range	DC-11GHz
VSWR	≤1.10(0-3G)
PIM Intermodulation@2-tonex20w	≤-160 dBc
Dielectric Withstanding Voltage	≥2500V RMS,50Hz,at sea level
Dielectric Resistance	≥5000MΩ
Contact Resistance	Center Contact ≤1.0mΩ Outer Contact ≤1.0mΩ

**Mechanical**

Durability Mating cycles ≥500 cycles

**Material and Plating**

	<b>Material</b>	<b>Plating</b>
Body	Brass	Tri-Alloy
Center conductor	Brass	Ag
Insulator	PTFE	-
Gasket	Silicone rubber	-
Other	Brass	Tri-alloy/Ni

**Environmental**

Installation Temperature CF	°C(°F)	-40 to 85(-40 to 185)
Storage Temperature CF	°C(°F)	-40 to 85(-40 to 185)
Operation Temperature CF	°C(°F)	-40 to 85(-40 to 185)
Watertightness		IP68
RoHS-compliance		Full RoHS Compliance
Salt-fog test		96h