



SPECIFICATION

7/16 MALE R/A CONNECTOR FOR 1/2"SF CABLE

7/16 (DIN) coaxial connectors – high-quality coaxial connectors with low attenuation and inter-modulation for frequencies up to 8.3 GHz. Transmission of medium to high power with radio transmitters and low PIM transmission of received signals such as in mobile phone base stations are typical applications due to their high mechanical stability and best possible weather resistance.

The 7-16 connector is the most rugged RF connection meeting all requirements even under the most severe environmental conditions. Sealing against outer conductor and jacket by means of the o-ring and 360° compression fit.

Watertight sealing in mated and unmated condition, i.e reduced efforts during installation and improved security during operation

Tri-alloy plating i.e. extreme resistance against corrosion even under hardest climatic and environmental circumstances

RoHS compliant can be used on a global basis

Standards		IEC60169-4	
Electrical Characteristics		Mechanical Characteristics	
Contact resistance inner conductor	≤0.4 mΩ	Recommended coupling torque	25-35Nm
Contact resistance outer conductor	≤0.2 mΩ	Durability (mating cycles)	≥500
Insulation resistance	≥ 10 GΩ	Material: spring contacts	Brass
Voltage proof	4.0KV/50Hz	Material: outer conductor	Brass
Impedance	50 Ω	Material: other metal parts	Brass
Return loss: Straight style	≥ 32 dB/4GHz; 19.1dB/6GHz	Material: insulators	PTFE
Return loss: Angle type	≥ 40 dB/1GHz; 19.1dB/6GHz	Plating: Inner conductor	Ag/Au
Working voltage	2.7KV/50Hz	Plating: Outer conductor	Ni/Tri-alloy
Frequency range up to	8.3GHz	Plating: Other metal parts	Ni/Tri-alloy

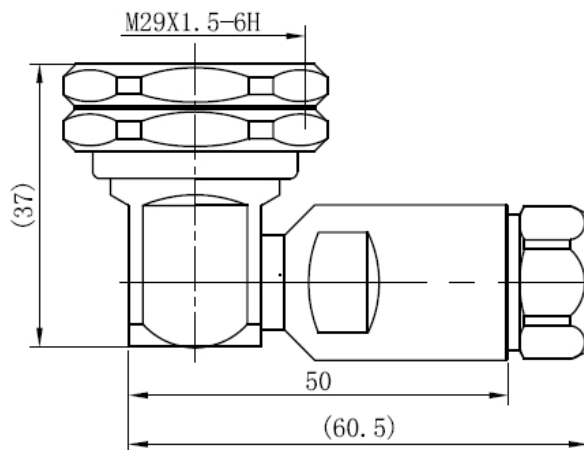

Part Number: 7/16-MA 1/2 HR

Dimensions are in millimeters

Interface

According to IEC 60169-4

General Specifications

Cable Size	1/2"
Cable Type	Superflexible
Connector Interface	7/16 DIN
Sealing Method	Sealing rubber and shrinking sleeve
Gender	Male

Electrical

Characteristic Impedance	50 ohm
Frequency Range	DC-7.5GHz
VSWR	≤1.12(0-3G)
PIM Intermodulation@2-tonex20w	≤-160 dBc
Dielectric Withstanding Voltage	≥4000V RMS,50Hz,at sea level
Dielectric Resistance	≥10000MΩ
Contact Resistance	Center Contact ≤0.4mΩ Outer Contact ≤0.2mΩ

Mechanical

Durability Mating cycles ≥500 cycles

Material and Plating

	Material	Plating
Body	Brass	Tri-Alloy
Center conductor	Brass	Ag
Insulator	PTFE	-
Gasket	Silicone rubber	-
Other	Brass	Tri-alloy/Ni

Environmental

Installation Temperature CF	°C(°F)	-40 to 85(-40 to 185)
Storage Temperature CF	°C(°F)	-40 to 85(-40 to 185)
Operation Temperature CF	°C(°F)	-40 to 85(-40 to 185)
Watertightness		IP68
RoHS-compliance		Full RoHS Compliance
Salt-fog test		96h